

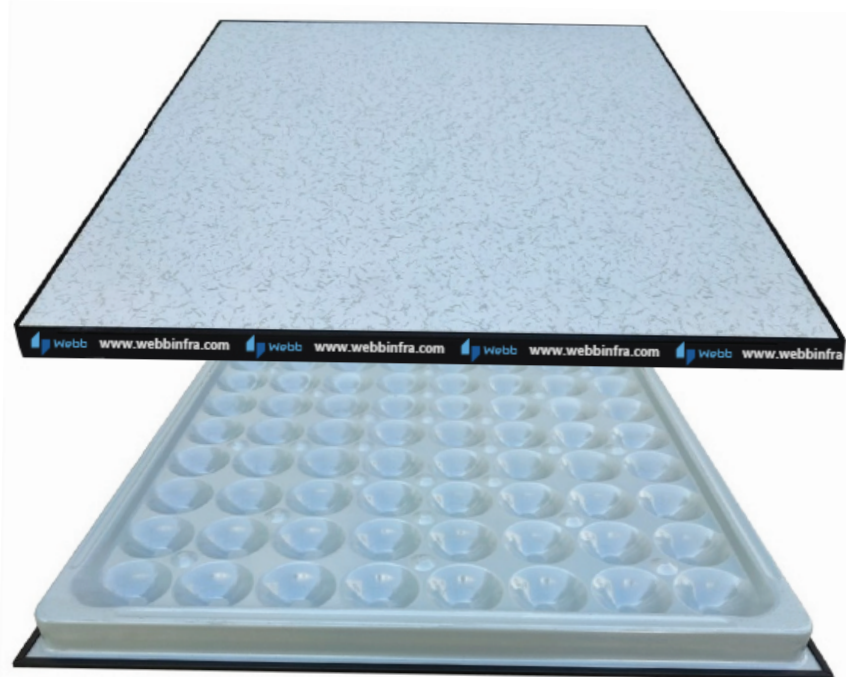

Raised Floor



DATA SHEET

☎ +44 20 8895 6455
✉ info@webbinfra.com
🌐 www.webbinfra.com

Anti-Static Steel Cement Raised Floor-HPL Finish

The Webb Anti-static Steel Cement Raised Floor with HPL Finish is designed for exceptional durability and stability, featuring a high-strength steel cement core. The top surface is coated with anti-static high-pressure laminate (HPL), providing effective resistance to electrostatic discharge. For added protection, the panels are equipped with anti-static conductive rubber trim on all four sides. The floor system is engineered to handle a variety of loads, including static, impact, rolling, and uniform loads, ensuring reliable performance in demanding environments. The system also includes zinc-galvanized pedestals and stringers for enhanced strength. With impressive load-bearing capacities and compliance with industry standards, this raised floor solution delivers reliable performance, safety, and electrostatic control for modern, mission-critical environments.

Specifications

- Fire resistance: ASTM E84-14 - Class A
- Panel core material: high-strength steel cement
- Panel top surface: anti-static high-pressure laminate (HPL)
- Panel edge protection: Anti-static conductive rubber trim on all four sides
- Static concentrated load: CISCA, PSA MOB PF2 - 360kg/3.56kN (medium grade)
- Ultimate load: 11.25kN
- Impact load: 45kg
- Rolling load: 2.94kN at 10 passes; 2.45kN at 10,000 passes
- Uniform load: 17.78kN/m²
- Axial load: 22.5kN
- Dimensions: 600mm x 600mm x 35mm
- Weight: 44-46kg/m²
- Meets CISCA, PSA MOB PF2, and ASTM E84-14 standards

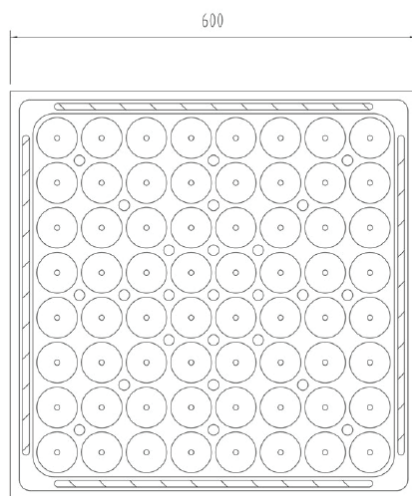

Bottom view

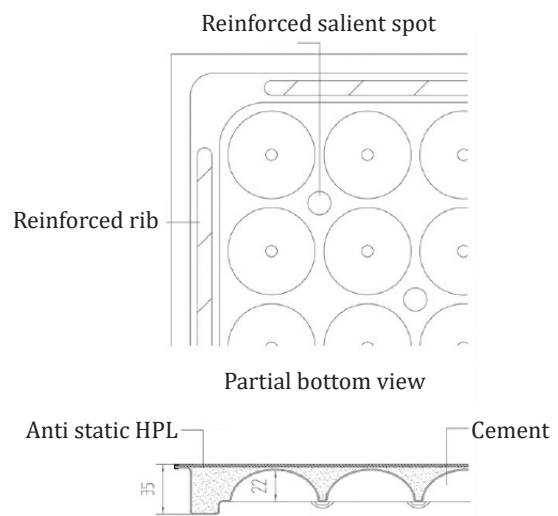

Partial section view

**Specifications are subject to change without notice based on technical recommendations and related product enhancements*

Pedestal and Stringer

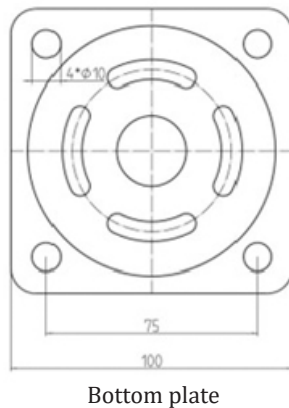
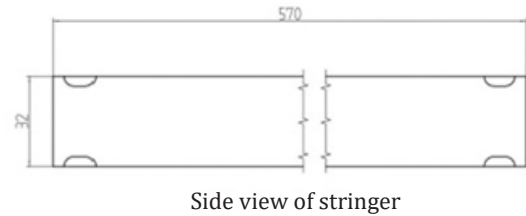
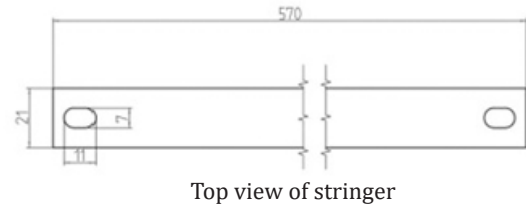
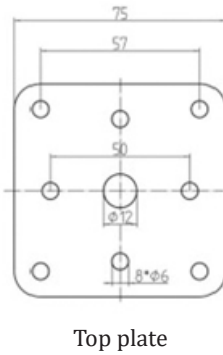
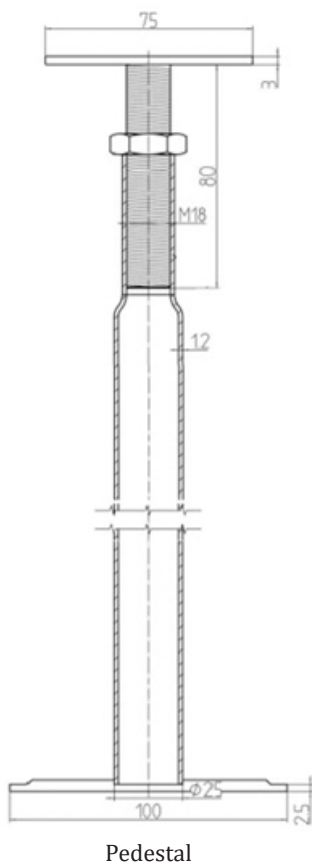
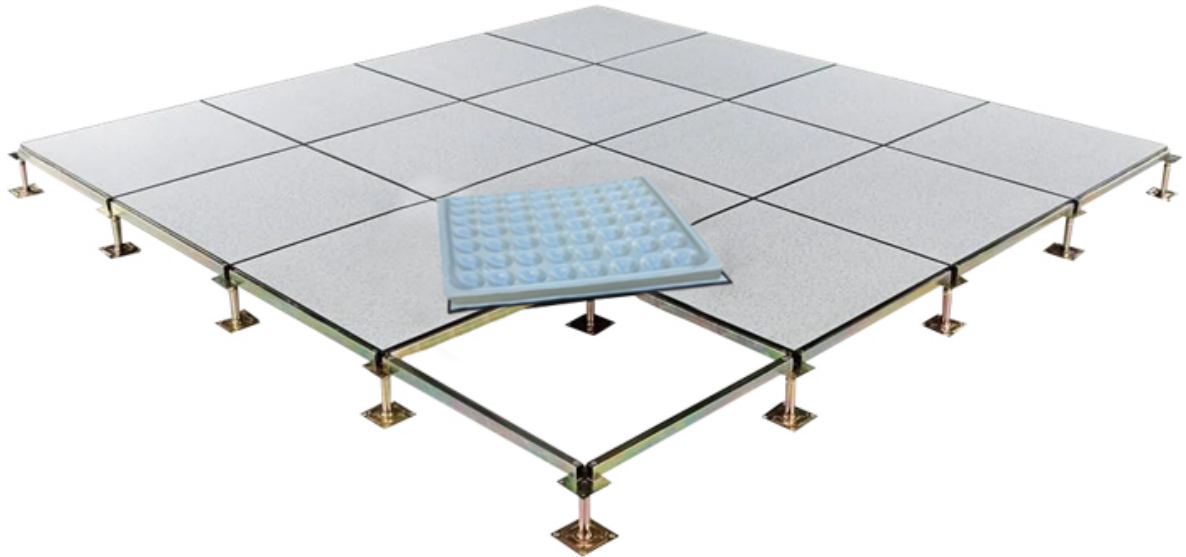

**Specifications are subject to change without notice based on technical recommendations and related product enhancements*